

L00003 SUPPORT HEAD

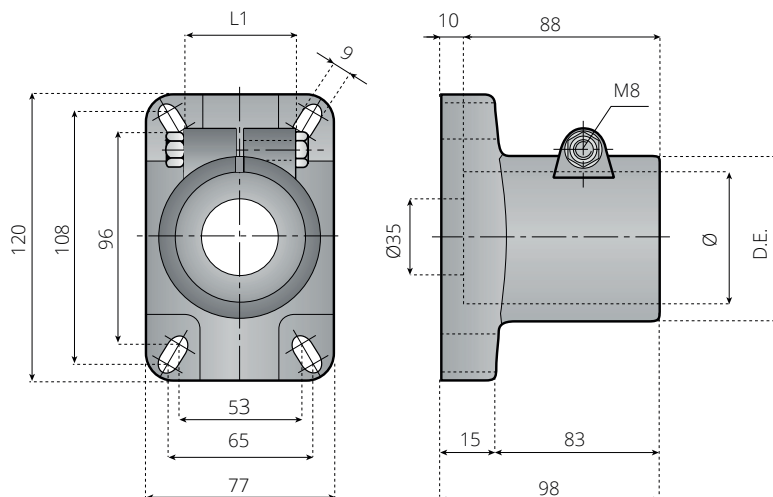

MATERIAL	D.E.	L1	TUBE Ø		
			48,3	50,9	60,3
CODE THEN DESCRIPTION					
PA-FG BLACK	77	50	L00003-00001 SUPPORT HEAD 48,3mm	L00003-00002 SUPPORT HEAD 50,9mm	L00003-00003 SUPPORT HEAD 60,3mm

MATERIAL: REINFORCED POLYAMIDE, SCREW, NUT AND WASHERS IN STAINLESS STEEL AISI 304.

NOTE: MAX. RECOMMENDED TIGHTENING TORQUE 2 KGM.

L00004 SIDE MOUNTING BRACKET

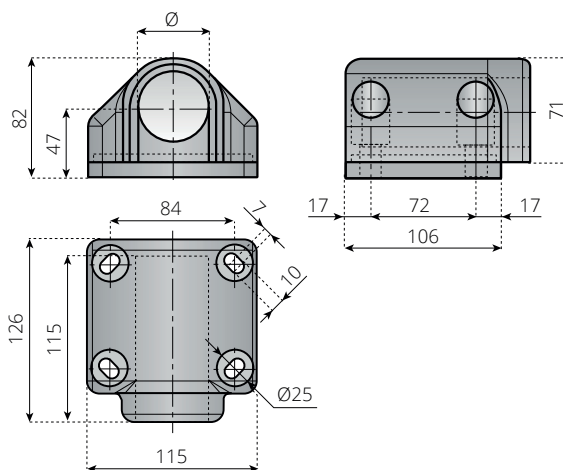

MATERIAL	TUBE Ø	
	48,3	50,9
CODE THEN DESCRIPTION		
PA-FG BLACK	L00004-00001 SIDE MOUNTING BRACKET 48,3mm	L00004-00002 SIDE MOUNTING BRACKET 50,9mm



MATERIALS



TABLE OF
CONTENTS



BACK TO FRAME &
STRUCTURE SUPPORT INDEX

WWW.IRP.CO.ZA