

L00005 ARTICULATED FEET/LEVELERS

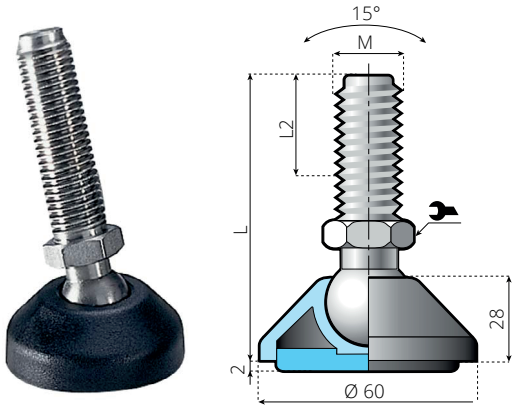

M	L mm	L2 mm	ANTI-SLIP WITH RUBBER
			CODE THEN DESCRIPTION ASSEMBLED
M12	104	66	L00005-00001 M12 - ANTI VIBR. FOOT COMP. 60 DIA.
M16			L00005-00002 M16 - ANTI VIBR. FOOT COMP. 60 DIA.

BASE: REINFORCED POLYAMIDE.
SPINDLE: STAINLESS STEEL 304.

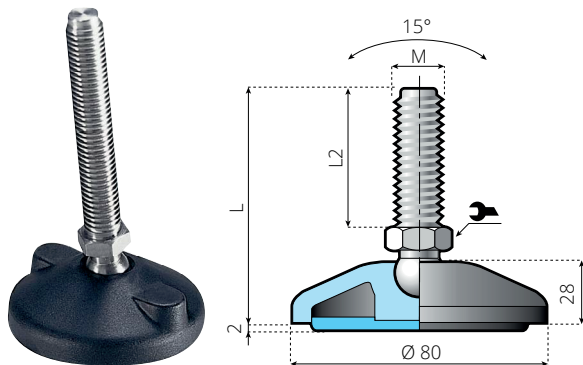

M	L mm	L2 mm	ANTI-SLIP WITH RUBBER
			CODE THEN DESCRIPTION ASSEMBLED
M12	104	66	L00005-00003 M12 - ANTI VIBR. FOOT COMP. 80 DIA.
M16			L00005-00004 M16 - ANTI VIBR. FOOT COMP. 80 DIA.

BASE: REINFORCED POLYAMIDE.
SPINDLE: STAINLESS STEEL 304.

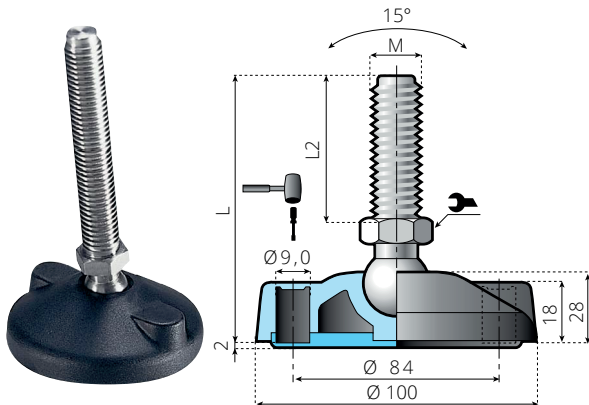

M	L mm	L2 mm	ANTI-SLIP WITH RUBBER
			CODE THEN DESCRIPTION ASSEMBLED
M12	104	66	L00005-00005 M12 - ANTI VIBR. FOOT COMP. 100 DIA.
M16			L00005-00006 M16 - ANTI VIBR. FOOT COMP. 100 DIA.

BASE: REINFORCED POLYAMIDE.
SPINDLE: STAINLESS STEEL 304.



MATERIALS



TABLE OF
CONTENTS



BACK TO FRAME &
STRUCTURE SUPPORT INDEX