

# CHAIN AND BELT RUBBER RETURN ROLLERS

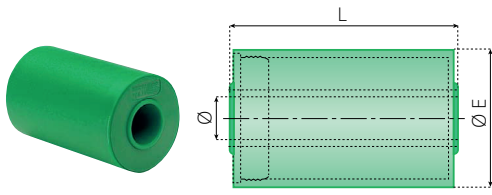

STANDARD VERSION

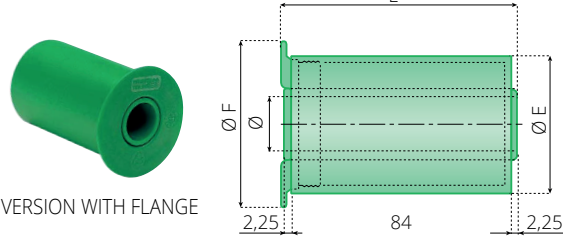

VERSION WITH FLANGE

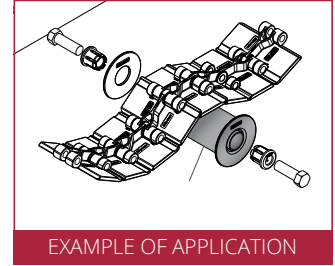

EXAMPLE OF APPLICATION

WATERTIGHT ROLLER						
MATERIAL	ØE	L	F	Ø 16	Ø 18	Ø 20
				CODE THEN DESCRIPTION		
<b>STANDARD VERSION</b>						
PE-HD GREEN	50	83	-	H00006-000015 R-50B16ML83-PEG	H00006-000017 R-50B18ML83-PEG	H00006-000019 R-50B20ML83-PEG
		85	-	H00006-000016 R-50B16ML85-PEG	H00006-000018 R-50B18ML85-PEG	H00006-000020 R-50B20ML85-PEG
	60	83	-	H00008-000009 R-60B16ML83-PEG	H00008-000011 R-60B18ML83-PEG	H00008-000013 R-60B20ML83-PEG
		85	-	H00008-000010 R-60B16ML85-PEG	H00008-000012 R-60B18ML85-PEG	H00008-000014 R-60B20ML85-PEG
<b>VERSION WITH FLANGE</b>						
PE-HD GREEN	50	88	65	H00006-000021 RF-50B16ML88-PEG	H00006-000022 RF-50B18ML88-PEG	H00006-000023 RF-50B20ML88-PEG
	60	88	80	H00008-000015 RF-60B16ML88-PEG	H00008-000016 RF-60B18ML88-PEG	H00008-000017 RF-60B20ML88-PEG

EXTERNAL DIAMETER

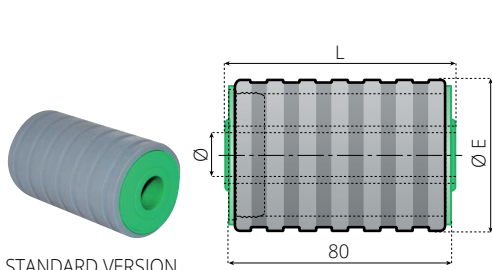

STANDARD VERSION

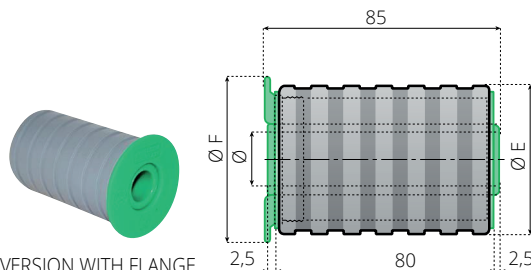

VERSION WITH FLANGE

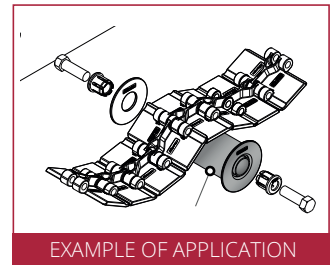

EXAMPLE OF APPLICATION

WATERTIGHT ROLLER WITH RUBBER						
MATERIAL	ØE	L	F	Ø 16	Ø 18	Ø 20
				CODE THEN DESCRIPTION		
<b>STANDARD VERSION</b>						
PE-HD GREEN	57	83	-	H00007-000001 RR-57B16ML83-PEG	H00007-000003 RR-57B18ML83-PEG	H00007-000005 RR-57B20ML83-PEG
		85	-	H00007-000002 RR-57B16ML85-PEG	H00007-000004 RR-57B18ML85-PEG	H00007-000006 RR-57B20ML85-PEG
<b>VERSION WITH FLANGE</b>						
PE-HD GREEN	50	85	65	H00007-000007 RRF-57B16ML85-PEG	H00007-000008 RRF-57B18ML85-PEG	H00007-000009 RRF-57B20ML85-PEG

EXTERNAL DIAMETER

## CHARACTERISTICS

**BOTH: LOW CO-EFFICIENT OF FRICTION, NO LIQUID ABSORPTION AND EXCELLENT WEAR AND CHEMICAL RESISTANCE.**  
**WATERTIGHT ROLLER WITH RUBBER: REDUCED NOISE LEVEL.**



MATERIALS



TABLE OF CONTENTS



BACK TO RETURN COMPONENTS INDEX

WWW.IRP.CO.ZA

# CHAIN AND BELT RETURN ROLLER FLANGES

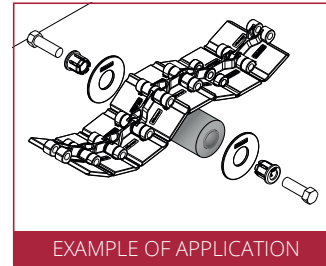
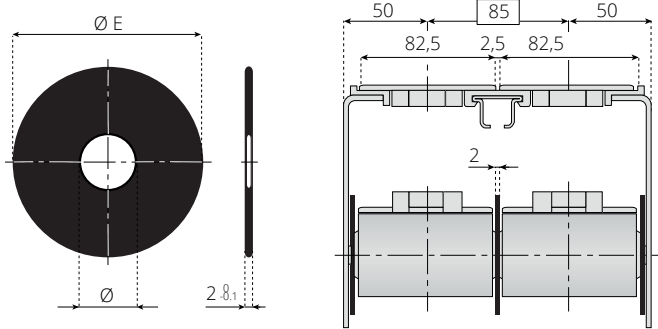

GUIDE FLANGE				
MATERIAL	ØE	FOR SHAFT		
		Ø 16	Ø 18	Ø 20
CODE THEN DESCRIPTION				
PP - BLACK	65	H000010-00001 F-65B16ML2-PPB	H000010-00002 F-65B18ML2-PPB	H000010-00003 F-65B20ML2-PPB
	80	H000010-00004 F-80B16ML2-PPB	H000010-00005 F-80B18ML2-PPB	H000010-00006 F-80B20ML2-PPB

## CHARACTERISTICS

- NO LIQUID ABSORPTION,
- EXCELLENT WEAR AND CHEMICAL RESISTANCE.